

# STAND UP FOR YOUR HEALTH

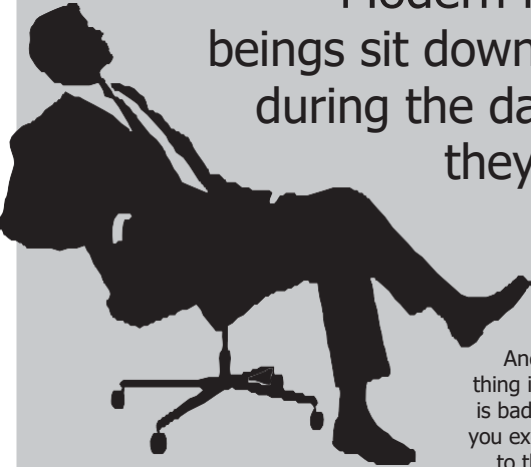

Modern human beings sit down more during the day than they sleep.

And the troubling thing is that inactivity is bad for you even if you exercise. Heading to the gym is not a license to spend the rest of the day on your backside.

**AN AVERAGE OF 9.3 HOURS A DAY**



Whether tending our crops or hunting wild boar, most of our lives as humans were lived on our feet.

But the advent of TV, computers, and the desk job, means we're sitting down more than ever before in history: **an average of 9.3 hours a day**. Our bodies weren't built for that, and it's starting to take its toll. You might want to join us, and stand up for this.

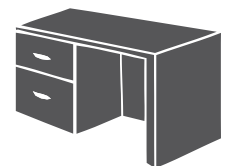

# THE KILLER POINT

Sitting 6 or more hours per day makes you up to **40% more likely to die** within 15 years, than someone who sits less than 3. Even if you exercise.



"People need to understand that the qualitative mechanisms of sitting are completely different from walking or exercising," says University of Missouri microbiologist Marc Hamilton. "Sitting too much is not the same as exercising too little. They do completely different things to the body."



## AS SOON AS YOU SIT:



Electrical activity in the leg muscles **shuts off**



Calorie burning drops to 1 per minute. Enzymes that help break down fat **drop 90%**



After two hours, good cholesterol **drops 20%**



After 24 hours insulin effectiveness **drops 24%** and the risk of diabetes rises



People with **sitting jobs** have **twice the rate** of cardiovascular disease as people with standing jobs. They're also more prone to depression: with less blood flow, fewer feel-good hormones circulate to your brain.

The human body simply isn't built to sit for long periods of time.



A hundred years ago, when we were all out toiling in the fields and factories, obesity was basically non-existent. But since we can't exactly run free in the fields until the end of our days, we have to help our bodies in other ways. We have to stand up for our right to stand up.

Galen Cranz, a professor at the University of California at Berkeley explains that the spine wasn't meant to stay for long periods in a seated position.

**Generally speaking, the slight S shape of the spine serves us well.**

**“But when you sit, the lower lumbar curve collapses, turning the spine’s natural S-shape into a C,**

hampering the abdominal and back musculature that support the body. The body is left to slouch, and the lateral and oblique muscles grow weak and unable to support it.”

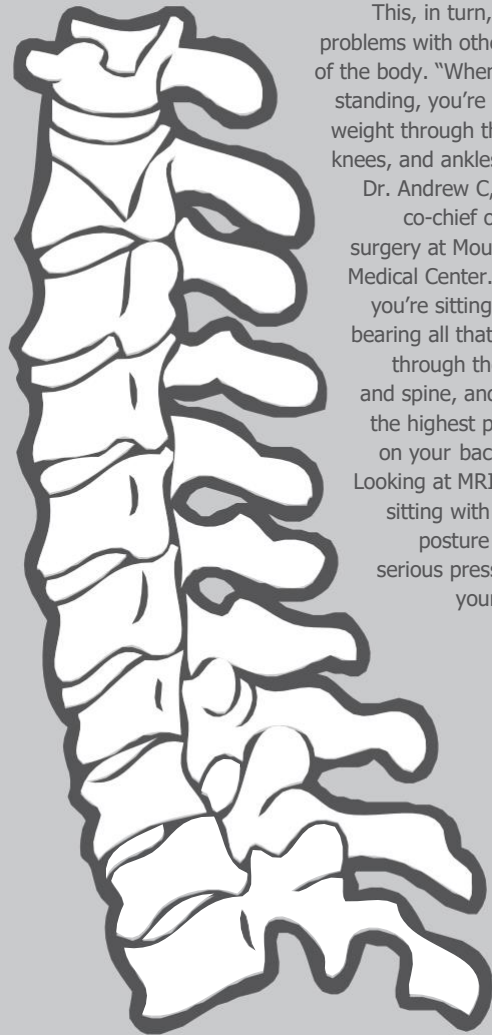

This, in turn, causes problems with other parts of the body. “When you’re standing, you’re bearing weight through the hips, knees, and ankles,” says Dr. Andrew C. Hecht, co-chief of spinal surgery at Mount Sinai Medical Center. “When you’re sitting, you’re bearing all that weight through the pelvis and spine, and it puts the highest pressure on your back discs. Looking at MRIs, even sitting with perfect posture causes serious pressure on your back.”

## AUSTRALIAN STUDIES



With Australians now sitting for about 80 per cent of their working days, Professor David Dunstan, of the Baker IDI Heart and Diabetes Institute, says sit-stand height-adjustable workstations make a significant impact.

**“If you can replace four hours of the work day sitting with standing, across a five-day working week, the net gain could be equivalent to a 45-minute brisk walk,”** he said.

Backed by the Heart Foundation, researchers simulated a work space at the Baker’s laboratory and examined 20 office staff working with regular periods standing up. Workers burnt 13 per cent more energy than when seated all day.

**BURN**

**MORE ENERGY**

## WHAT ENCOURAGES EMPLOYEES TO STAND MORE?

The Stand@Work study, a joint University of Sydney and Heart Foundation research project, involved desk-based office workers in the Heart Foundation Sydney Office trialing a sit-stand workstation for a four week period at work. Study participants talked about a range of factors that encouraged them to use the workstation in the standing position. These included:

- The ease of moving the workstation up and down.
- Wearing comfortable, flat shoes.
- Feeling physical benefits, such as less back pain, from sitting less.
- Feeling more energetic and alert, especially later in the working day.
- Perceived improvements in productivity from working while standing.
- Seeing others standing, which acted as a visual prompt to also stand up.
- A supportive work environment that accepted standing as normal practice, even in an open plan office.
- Formation of a new habit over time, and developing the physical capacity to gradually stand for longer periods.

The Stand@Work study was successful in reducing sitting time and increasing standing time by about an hour each work day, among those who trialed the workstation. From this study, sit-stand workstations are shown to be a feasible option for reducing sitting time in office based workers. Most of the study participants said they would keep using the workstation if they had the option. Study participants felt less self-conscious about standing, as more people trialed the workstation, indicating that it is possible to create a 'sit less' culture among office workers.



# STANDING WORKSTATIONS SHOULD BE CONSIDERED

"Officewise: a guide to health and safety in the office" (Comcare, July 2008) recommends that standing-height work surfaces be adjustable to accommodate the height differences of the range of people using them. Comcare recommends, in general, a standing-height work surface be between 850mm and 950mm high.

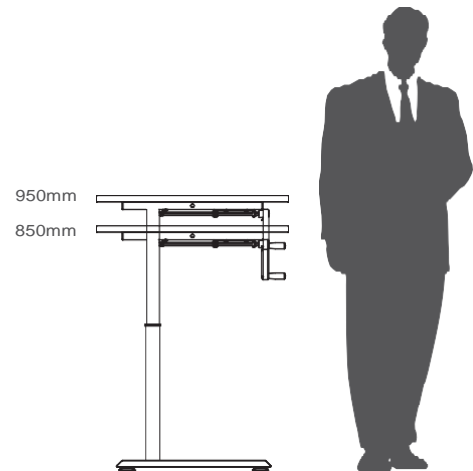

Colourwise Office Supplies is unique in that it offers a complete sit-stand solution with an amazing height range of 660mm – 1060mm high. Colourwise Office Supplies "Axis" range of both stand-alone workstations and integrated benching system offers a wind-up user adjust action or a push-button, fully electric user adjust action. Both options are easily adjustable from the seated or standing position.



Colourwise Office Supplies is serious about combating this modern day health dilemma. Colourwise Office Supplies own staff are pioneers in using sit-stand workstations. We invite you to join us. Spread the word and make a difference. Stand up.

